

Low Profile Cylinders

HL Series - Low Clearance Lifting

- Compact design for use in confined spaces.
- Plunger wiper helps seal out dirt and contamination.
- Specially designed return spring provides quick retraction and extends the life of the spring.
- Hard chrome plated plunger helps prevent scratching and corrosion.
- Plunger end is grooved to reduce load slippage.
- Includes high flow coupler and dust cap.
- HL1001, HL2002, and HL3002 coupler is tilted 5° for added clearance.



HL Series

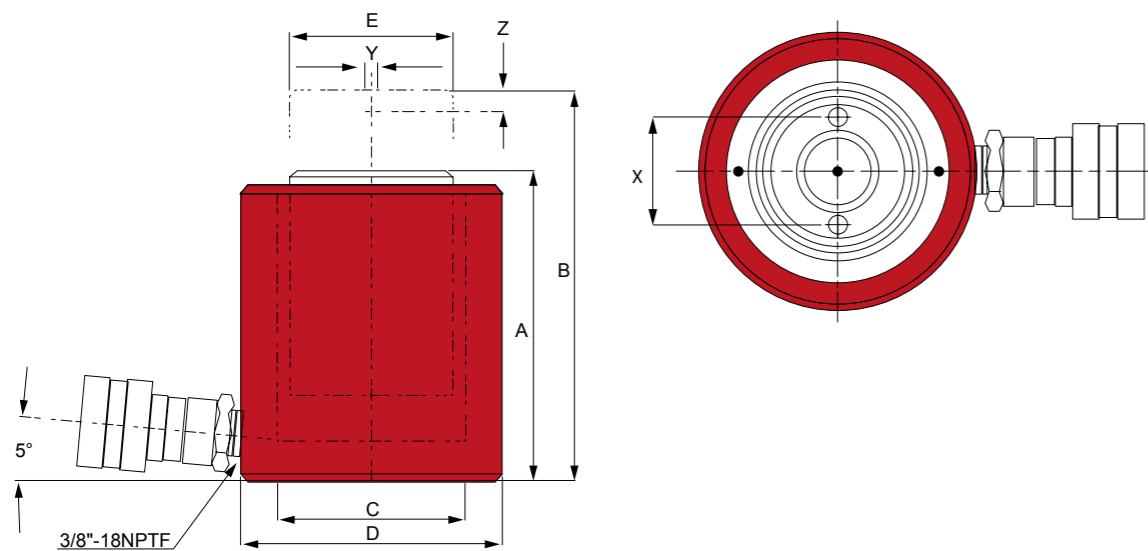

Low profile cylinders are great for confined spaces.

Cylinder Capacity	Stroke (mm)	Model Number	Cylinder Effective Area (cm ²)	Oil Capacity (cc)	Weight (kg)
10 Tonne 104 kN	38	HL1001	15.2	58	2.6
20 Tonne 194 kN	44	HL2002	28.2	125	5.0
30 Tonne 288 kN	62	HL3002	41.9	260	6.8
45 Tonne 437 kN	60	HL5002	63.7	382	9.9
90 Tonne 870 kN	57	HL10002	126.7	722	20.6



Model Number	Collapsed Height A (mm)	Extended Height B (mm)	Cylinder Bore Diameter C (mm)	Outside Diameter D (mm)	Plunger Diameter E (mm)	Plunger Mounting		
						Bolt Circle X (mm)	Thread Y	Thread Depth Z (mm)
HL1001	89	126	44	70	38	26	M4	8
HL2002	99	144	60	92	51	40	M5	8
HL3002	117	179	73	102	64	40	M5	8
HL5002	122	182	90	124	70	40	M5	8
HL10002	141	198	127	165	90	56	M8	3

Low Profile Cylinders Combo Kit

Low Clearance Lifting



▲ Press truck wheel from nave with the mini-press. Fits between the chassis and wheel.

- Compact design for use in confined spaces.
- Ideal for pushing applications.
- Plunger wiper helps seal out dirt and contamination.
- Return spring ensures a quick retraction and extends the life of the spring.
- Industrial hard chrome plated plunger helps prevent scratching and corrosion.
- Includes stackable 1", 2", and 3" aluminum adapters that conveniently snap into the base of the plunger.
- Includes high flow CH38F coupler and dust cap.
- Convenient storage case.

HL Series



Safety Practices
 Good industry practice recommends not exceeding 80% of maximum rated capacities of all our products.

Related Product: Hoses
 We offer a variety of hoses, fittings, lengths and materials. pg 73

High-Flow Couplers
 High-Flow Coupler: CH38F is included on all models (except where specified).

Cylinder Capacity	Model Number	Stroke (mm)	Cylinder Effective Area (cm ²)	Collapsed Height (mm)	Extended Height w/o adapter (mm)	Internal Pressure at Capacity (BAR)	Cylinder Housing Diameter (mm)	Plunger Diameter (mm)	Weight (kg)
10 Tonne 106 kN	HL1001D	38	15.16	88	126	0.59	70	38	4.5

Bolt-On Tilt Saddles

Bolt-on tilt saddles are designed specifically for use with the HL Series Low Profile Cylinders and Low Profile Cylinder Kit. These saddles provide a max. 5° tilt for uneven loads.

Model Number	Height (mm)	Description
SDTL10	21	HL1001 Cylinder Kit
SDTL50	29	HL2002 / HL3002 / HL5002 Cylinder
SDTL100	35	HL10002 Cylinder